

Low distortion of output waveform from new 10 c/s - 10 Mc/s solid-state Test Oscillator is typically well below -40 dB throughout major part of broad frequency range. In addition to low distortion, Test Oscillator has excellent amplitude stability, uniform frequency response, and 90-dB calibrated attenuator with both 50-ohm and 600-ohm outputs for increased wideband measurement flexibility. (This is Fig. 1 of article beginning on page 2.)

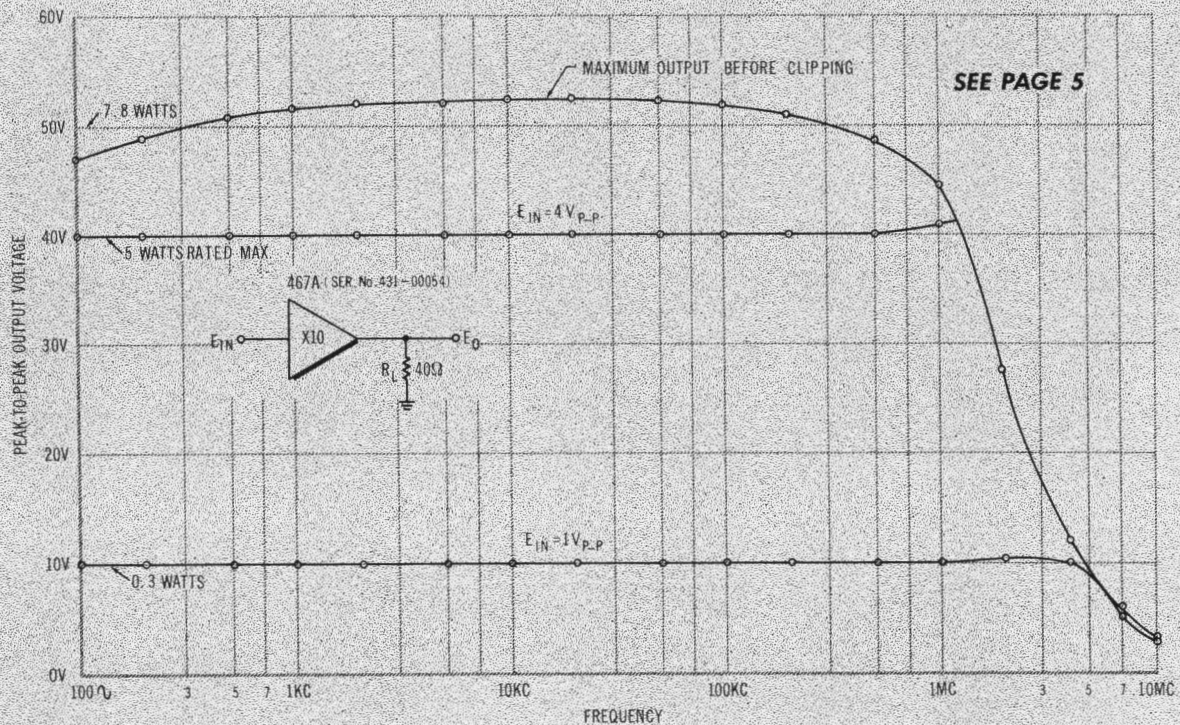

Maximum power output vs. frequency of typical -hp- Model 467A Power Amplifier is shown by upper curve, which plots maximum voltage obtainable without waveform clipping. Other curves show output voltage vs. frequency with constant level input. General purpose power amplifier combines stable DC-coupling with response to well beyond 1 Mc/s. (This is Fig. 2 of article beginning on page 5.)

A NEW 10c/s-10Mc/s TEST OSCILLATOR WITH ENHANCED OUTPUT CAPABILITIES

The performance possible with state-of-art techniques has been incorporated in a general-purpose test oscillator.

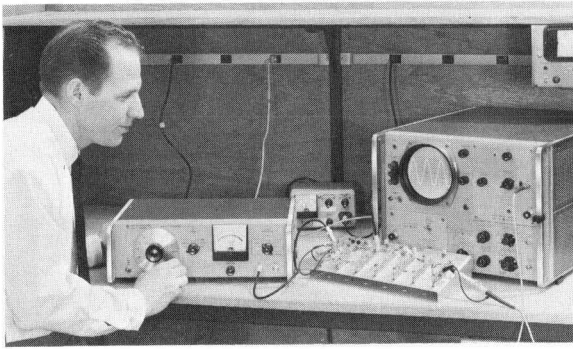

Fig. 2. Solid-state test oscillator has wide frequency range and output flexibility required by laboratory applications. Accurate attenuator and monitor meter assure well-defined output power levels. New test oscillator has frequency and amplitude stabilities of high order.

ONE OF THE workaday helpmates of many laboratories has been the *-hp-* Model 650A Test Oscillator, an instrument that is widely appreciated as an easy-to-use, reliable, source of sine waves from 10 c/s to 10 Mc/s. By virtue of its 1,000,000 to 1 frequency range, the Model 650A has found extensive use as a basic laboratory tool in testing circuits in the audio, ultrasonic, video and radio frequency ranges, in wide-band response testing of filters, transformers and broadband amplifiers, or in just plain tinkering.

Now, a new wide-range test oscillator, one that uses new solid-state components to achieve improved performance, has been designed in the *-hp-* Loveland laboratories. This lightweight instrument likewise has a 10 c/s-10 Mc/s frequency range, a 6-volt open-circuit output capability, and an output that is matched for 600-ohm loads, but it also has a second output capable of supplying up to 200 mW

into a matched 50-ohm load. However, it is not necessary that a load be matched to either output, as the oscillator can drive any load impedance without distortion, including more than 60 mA rms into a short circuit.

The amplitude of the signal delivered by the new oscillator is exceptionally stable, varying typically less than $\pm 0.1\%$ from nominal in a 17-hour period (Fig. 3). Stability of this constancy is especially appreciated when the oscillator is used as a power source for af or rf bridge measurements or in other precision measurements where small changes in the test signal amplitude could affect the measurement significantly.

The oscillator has a highly accurate output attenuator with a range of 90 dB in 10-dB steps, enabling the instrument to supply calibrated voltages from 10 μ V to over 3 V rms into matched loads from either output. An output monitor meter that is specified

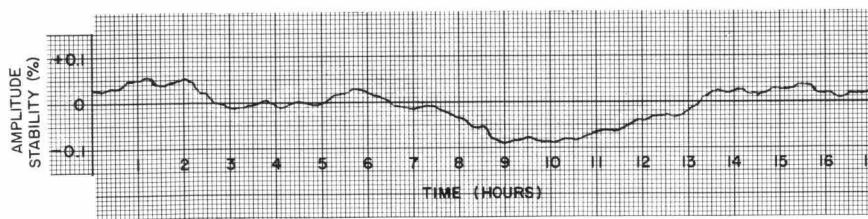

Fig. 3. Plot of typical amplitude stability of new Test Oscillator shows variations less than $\pm 0.1\%$ for 17-hour period.

with regard to accuracy is included, a fact which places this new instrument in the class of signal generators, even though by convention it is called a test oscillator.

In other respects as well, the new oscillator attains higher levels of performance. The frequency response varies less than $\pm 2\%$ and the distortion is less than 1% over most of the frequency range. Short term frequency stability is typically within 10 ppm and total hum and noise is less than 0.05% of the output. On the whole, the new oscillator supplies a high quality, stable waveform over a wide frequency range.

OUTPUT IMPEDANCE

The 50-ohm output is of special interest because of the flexibility it allows in oscillator usage. Transmission-line analysis has shown that the voltage at the far end of a lossless line matched to the source is independent of frequency and line length and, as long as the load is resistive, the output voltage is affected only by the ratio of the load and source impedances. If the load is reactive, the output is also affected by frequency but is independent of line length. The oscillator thus may be brought directly to a distant load, in effect, simply by carrying the oscillator signal on a cable matched to the oscillator output.

The impedance of the load, whether reactive or resistive, whether high or low, has negligible effect on the performance of the oscillator. The oscillator is able to drive any load impedance through either output without distortion or frequency "pulling." As mentioned previously, it can drive a short circuit, supplying undistorted current sine waves of more than 60 milliamperes rms at any frequency through the 50-ohm output.

The instrument can be source-matched to any cable impedance Z_o higher than 50 ohms simply by addition of an appropriate padding resistor R_s in series with the 50-ohm output ($R_s = Z_o - 50$). It is thus possible to use the oscillator for testing 135-ohm carrier system telephone lines and 900-ohm local subscriber loops as well as the 600-ohm program lines.

OUTPUT CIRCUITS

The wide-range output attenuator has four 50-ohm pi-sections, two of which are designed for 30 dB of attenuation, one for 20 dB and one for 10 dB. The attenuator switch cascades the sections in various combinations to reach 90 dB attenuation in 10-dB steps. The attenuator is accurate within ± 0.1 dB at all settings, an accuracy that makes the oscillator well-suited for measuring the range-to-range tracking accuracy of AC voltmeters. The frequency response of the attenuator is flat throughout a frequency range well beyond that of the oscillator itself.

The average-responding monitor meter reads the input voltage to the attenuator with an accuracy of $\pm 2\%$ of full scale and with a frequency response flatness that varies less than $\pm 1\%$ from 20 c/s to 4 Mc/s. The flat response of the meter, in conjunction with the excellent amplitude stability and frequency response of the oscillator, makes the new instrument well suited for calibrating AC voltmeters over a wide frequency range. The oscillator need be calibrated at only one frequency, and it may then be swept manually through the frequency range of an AC voltmeter to find any peaks or dips in the voltmeter response. Oscillator response is particularly constant throughout the all-important audio range.

CIRCUIT FUNDAMENTALS

A block diagram of the new wide-range test oscillator is shown in Fig. 4. The master oscillator-power amplifier circuit configuration is used to isolate the oscillator from the load. In the oscillator section, positive feedback for sustaining oscillations is supplied from the oscillator amplifier to a capaci-

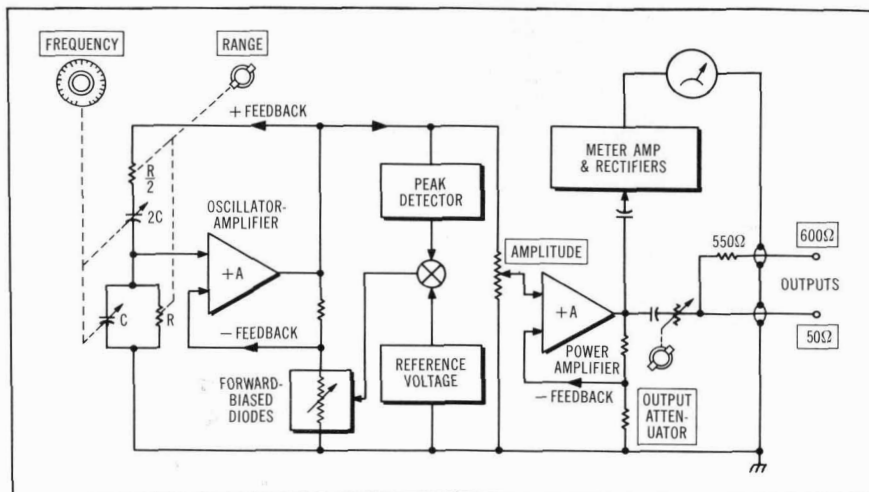

Fig. 4. Block diagram of Model 651A Test Oscillator.

tively-tuned Wien bridge that establishes the operating frequency.

Negative feedback, which assures waveform purity by limiting the oscillation amplitude to the linear operating range of the transistors, is applied through an amplitude-controlled circuit. Forward-biased diodes serve as variable resistances in the negative feedback path to control the feedback ratio, as in the popular *-hp-* Model 204B 5 c/s-600 kc/s transistorized Oscillator.¹ Diode bias is closely regulated by a circuit that derives a control signal from comparison of the oscillator output to the stable breakdown voltage of a zener diode. An exceptionally high degree of amplitude stability is thus achieved.

The tight control of the output amplitude also contributes to the flat frequency response, which is level within $\pm 2\%$ between 100 c/s and 4 Mc/s, within $\pm 3\%$ between 10 and 100 c/s, and within $\pm 4\%$ between 4 and 10 Mc/s.

¹ David S. Cochran, "The Transistorized RC Oscillator," *Hewlett-Packard Journal*, Vol. 13, No. 5, Jan., 1962.

The power amplifier is almost identical in design to the oscillator-amplifier, including a complementary-symmetry emitter-follower pair in the output stage, but it is capable of larger voltage swings and much more output power, up to 200 mW into a 50-ohm load. A potentiometer between the oscillator and the power amplifier provides more than 20 dB of continuous amplitude control for interpolating between the steps of the output attenuator.

SOLID-STATE CIRCUITRY

While attaining the definite advantages of reliability, ruggedness, light weight, and cool operation, the use of recently-developed solid-state circuitry in the new instrument has also realized important improvements in performance. The oscillator-amplifier, with the aid of new high frequency transistors and a boot-strapped differential amplifier in the front end, has a frequency response that extends to 35 Mc/s at the 3-dB point. The phase shift at 10 Mc/s thus is negligible, even when driving

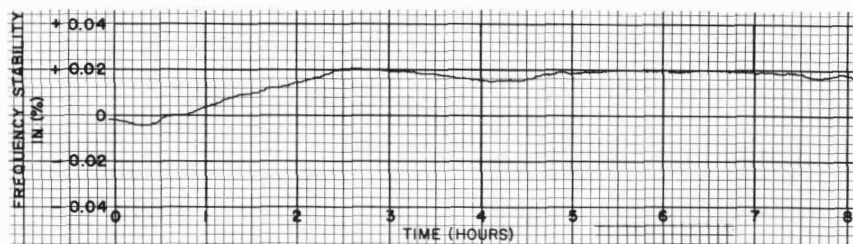

Fig. 5. Typical frequency stability of Model 651A Test Oscillator at 5 Mc/s is shown for an 8-hour period.

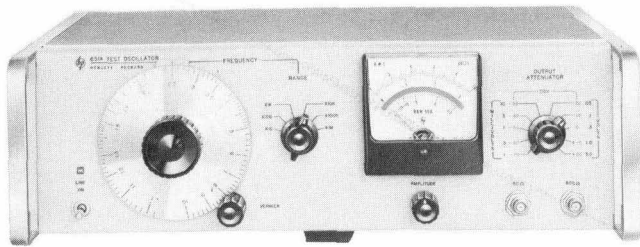

Fig. 6. New -hp- Model 651A Test Oscillator has calibrated outputs for either 50 or 600 ohms but can drive any load impedance without distortion throughout 10 c/s to 10 Mc/s frequency range. Options provide for outputs calibrated for and matched to higher impedances.

the low impedance of the Wien bridge at that frequency. The advantages of the Wien bridge oscillator circuit, i.e., low distortion, high stability, and flat frequency response, are thereby made

available up to 10 Mc/s. In the new oscillator, distortion is less than 1% from 10 c/s to 5 Mc/s and is no more than 2% at 10 Mc/s (see Fig. 1, front page). With total distortion products of this low order, the oscillator is well-suited for testing circuit linearity. Frequency stability is as high as 10 ppm at 5 Mc/s in a normal room environment, as shown in Fig. 5, and is even better than this at lower frequencies.

Low impedance transistor circuitry, however, severely loads a capacitively-tuned Wien bridge at low frequencies where the impedance of the bridge is high. For instance, to oscillate at 10 c/s with a typical 600 pf variable air capacitor, the bridge resistors have to be about 26 megohms ($f_0 = 1/2\pi RC$). For this reason, earlier transistorized RC oscillators used fixed capacitors of relatively large size and are tuned by variable resistances of a value compatible with transistor circuitry.

The field-effect transistor (FET) now makes available a solid-state circuit that has an input impedance of over 2500 megohms. The low-noise FET in the new test oscillator is connected as a "source-follower," the FET equivalent of the emitter-follower, to couple the high impedance Wien bridge to the low impedance transistor amplifiers on the low-frequency ranges. Thus it is that the new -hp- Model 651A Test Oscillator can use a capacitively-tuned Wien bridge to span the entire frequency range from 10 c/s to 10 Mc/s with an all solid-state oscillator-amplifier.

MONITOR METER

The monitor meter is driven by an amplifier that has a boot-strapped collector load. The amplifier therefore functions as a linear high-impedance

current source that is insensitive to temperature-induced changes in resistance of the copper meter coil.

The voltage scale of the meter is calibrated when either the 50-ohm or 600-ohm output is properly loaded. A 50-ohm feedthrough termination (-hp- Model 11048B) may be used to obtain a calibrated output when driving high impedance loads.

The dBm scale normally is calibrated to read the power delivered to a 50-ohm system, and optional meter circuits with the dB scale calibrated for operation with 600-ohm systems have been designed. Meter and attenuator circuitry for a 75-ohm output have also been designed and, on special order, the instrument may be built for calibrated operation with higher impedances.

GENERAL

The backlash-free FREQUENCY dial has an indicia that lies in the same plane as the dial to eliminate parallax, thus achieving accurate setability and resetability. Accuracy of dial setting is better than 3% throughout the entire frequency range, including warm-up drift and $\pm 10\%$ power line variations, and is better than 2% between 100 c/s and 4 Mc/s.

ACKNOWLEDGMENTS

The design team for the new -hp- Model 651A Test Oscillator consisted of project leader Noel Pace, product designer Kay Danielson, and electrical engineers Don Pauley, James Colwell, and the undersigned. Many helpful suggestions and ideas were provided by Marco Negrete.

-Myles A. Judd

A biographical sketch of the design leaders for the new Test Oscillator appears on p. 8

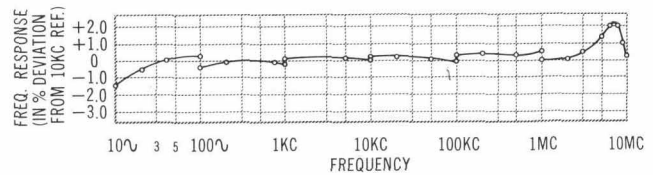

Fig. 7. Typical frequency response of new wideband Test Oscillator with fixed setting of Amplitude and Attenuator controls. Adjusting Amplitude control to maintain monitor meter at constant deflection enables output level to be held within better than 1% up to 4 Mc/s.

SPECIFICATIONS

-hp- MODEL 651A TEST OSCILLATOR

FREQUENCY RANGE: 10 c/s to 10 Mc/s, 6 bands; dial calibration: 1 to 10.

DIAL ACCURACY (including warm-up drift and $\pm 10\%$ line variations):
 $\pm 2\%$, 100 c/s to 1 Mc/s
 $\pm 3\%$, 10 c/s to 10 Mc/s

FREQUENCY STABILITY: Typically 10 ppm/minute.

OUTPUT: 200 mW (3.16 V into 50 ohms); 16 mW (3.16 V into 600 ohms); 6.32 V open circuit.

DISTORTION: Less than 1% 10 c/s to 5 Mc/s, approximately 2% at 10 Mc/s.

HUM AND NOISE: Less than .05% of maximum rated output.

OUTPUT MONITOR: Voltmeter monitors level at input to attenuator in volts or dB. Top scale calibrated in volts. Bottom scale calibrated in dB.

ACCURACY: $\pm 2\%$ at full scale.
FLATNESS:
 $\pm 1\%$ at full scale, 20 c/s-4 Mc/s.
 $\pm 2\%$ at full scale, 10 c/s-10 Mc/s.

FREQUENCY RESPONSE:

Flat within: $\pm 2\%$ 100 c/s to 1 Mc/s.
 $\pm 3\%$ 10 c/s to 100 c/s.
 $\pm 4\%$ 1 Mc/s to 10 Mc/s.

AMPLITUDE CONTROL: 20 dB range (nominal).

ATTENUATOR:

RANGE: 90 dB in 10-dB steps.
OVERALL ACCURACY: ± 0.1 dB.
 $Z_0 = 50$ ohms and 600 ohms.*

TEMPERATURE RANGE: 0°C to +50°C.

SIZE: Nominally 5¼ in. high x 16¾ in. wide x 13¼ in. deep.

WEIGHT: Net, 17 lbs. (7.65 kg). Shipping, 22 lbs. (9.90 kg).

POWER: 115V/230V $\pm 10\%$, 20 watts, 50 to 1000 c/s.

PRICE:

-hp- 651A, \$590.00.

Option 01: Output Monitor top scale calibrated in dBm/600Ω. Bottom scale calibrated in volts. \$615.00.

Option 02: Output impedance: 75 ohm and 600 ohm. Output monitor top scale calibrated in dBm/75Ω. Bottom scale calibrated in volts. \$615.00.

ACCESSORIES AVAILABLE (Not furnished):

11005A Line Matching Transformer for balanced 600-ohm lines, 20 c/s-45 kc/s (\$80.00).

11004A Line Matching Transformer for balanced 600-ohm or 135-ohm output, 5-600 kc/s (\$60.00).

11001A Cable, male NBC to dual banana plug (\$5.50).

11048B 50-ohm Feed-thru Termination (\$10.00).

Prices f.o.b. factory
 Data subject to change without notice

* Other output impedances above 50 ohms available on special order.

A LOW-DISTORTION AMPLIFIER SUPPLYING 10 WATTS PEAK FROM DC TO BEYOND 1 Mc/s

A new amplifier has sufficient bandwidth to enable it to serve at dc or RF and sufficient power to be used as an electro-mechanical driver.

A WIDE-BAND power amplifier can perform a number of useful functions in instrumentation set-ups. It can increase the signal power from oscillators or other signal sources for directly driving long transmission lines, galvanometers, magnetic tape recording heads, memory cores, transducers, or other electro-mechanical devices. It can serve as an RF power amplifier and, if it also has dc capability, it is useful as a data amplifier or as a driver for servomotors in breadboard set-ups.

In response to the demand for an amplifier that has both power capability and wide frequency response, a new wideband power amplifier has been developed in the *hp*- Laboratories. This amplifier has a rated ac power capability of 5 watts over a frequency range from 0 to beyond 1 Mc/s, and at dc or on ac peaks it is capable of 10 watts output. It has an output impedance that is virtually zero, actually less than 0.005 ohms in series with 1 μ H, and it is thus able to drive practically any load impedance within its 40 volt and 1 ampere peak-to-peak ratings.

The gain of the new amplifier is controlled by a front panel switch in four steps, $\times 1$, $\times 2$, $\times 5$, $\times 10$. Gain accuracy is within 0.3% of the indicated setting for the fixed gain positions but a variable position allows selection of any value of gain between 0 and 10.

Distortion in the new amplifier has been held to an extremely low level.

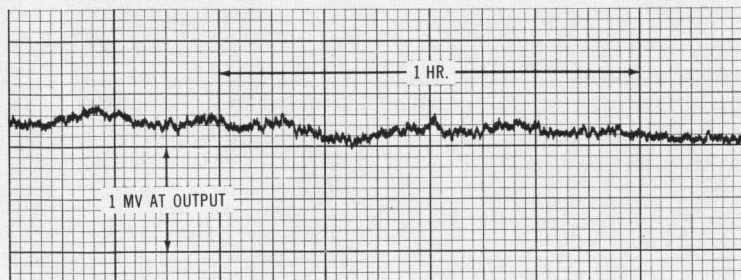

Fig. 3. Graph shows typical dc stability of new wideband Power Amplifier. (Noise at output is independent of gain setting.)

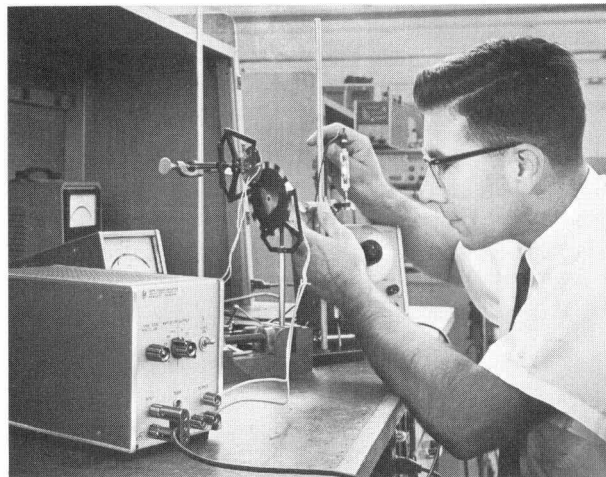

Fig. 1. New Model 467A Power Amplifier (foreground) combines dc coupling and greater than 1 Mc/s response with power capability. Here it increases output power of test oscillator for driving synchronous motor in frequency response test of photodetectors. New amplifier also serves as ± 20 V, $\frac{1}{2}$ -amp power supply.

Distortion is less than 0.01% at 1 kc/s, even at full power output, and at 100 kc/s, it is less than 1%. Amplitude linearity is within 0.01% at a full output of 1 ampere peak-to-peak from dc to 1 kc/s, and within 0.5% up to 100 kc/s. In addition, the dc drift is low, the output level changing less than $\pm 0.01\%$ of the full scale range per degree C.

ACCIDENT-PROOF

The amplifier is designed to be virtually indestructible from overloads or abnormal signal levels, a desirable feature when it is to be used for breadboard applications in the laboratory. It survives without damage input volt-

ages as high as 200 volts p-p and is not at all harmed by short circuits across the output terminals. To protect delicate components that may be connected to the output terminals, special circuitry is included to eliminate turn-on and turn-off transients.

DC POWER SOURCE

The amplifier also serves as a power supply capable of supplying ± 20 V with a regulated output that changes less than 10 mV for a 0-to- $\frac{1}{2}$ ampere change in output current. Because of its dc coupling, its low output impedance and $\frac{1}{2}$ -ampere dc capability, it

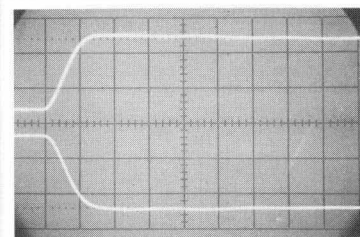

Fig. 4. Oscilloscope shows typical step response of new Power Amplifier driving 40-ohm load for both positive and negative 1-volt steps at input. Sweep speed: 0.1 μ s/cm; vertical sensitivity: 5 V/cm.

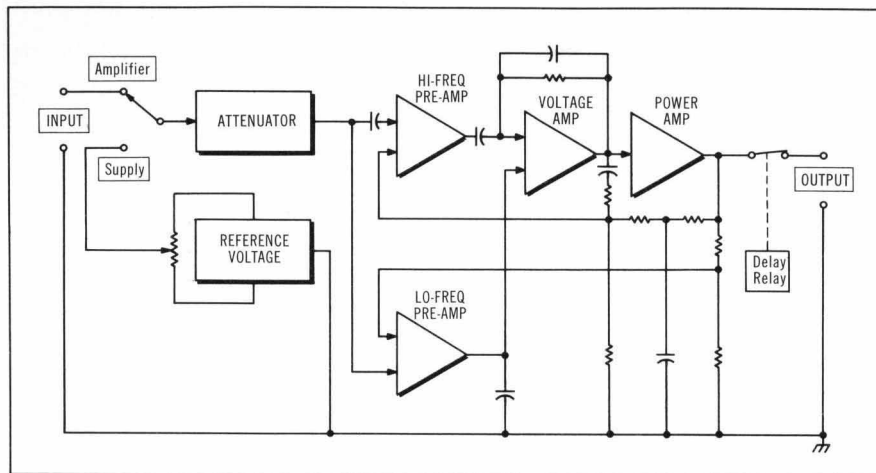

Fig. 5. Simplified block diagram of *hp-Model 467A Wideband Power Amplifier*. Use of separate pre-amps for low and high frequencies insures wideband response with dc stability.

was a simple matter to increase the amplifier's versatility in this way simply by including a reference voltage in the circuit design to control the output voltage. The reference voltage is switch-controlled from the front panel, allowing the full scale power supply output to be set from ± 1 V to ± 20 V. A vernier control provides 0.1% resolution in each position.

An interesting characteristic of the instrument as a power supply is that the vernier control can sweep continuously through the whole range from maximum negative to maximum positive volts. The output voltage polarity may thus be changed without switching or lead changing, a useful feature in semiconductor diode testing, for example, where a continuous sweep from reversed bias to forward bias is required.

CIRCUIT DESIGN CONSIDERATION

The new Power Amplifier has separate pre-amplifiers for the low and high frequencies, as shown in the block diagram of Fig. 5. This allows the transistors in the high frequency pre-amp to be biased for optimum high fre-

quency performance while at the same time the transistors in the low frequency pre-amp can be operated at low current levels to minimize drift. Thus, low dc drift and flat high frequency response are both obtained. Over 80 dB of feedback is employed in a multiple-loop circuit configuration to maintain low distortion and stable gain.

The dc stability of the new amplifier is shown by the strip chart recording in Fig. 3. The excellent high frequency performance is attested to by the step response shown in the oscillogram of Fig. 4. Risetime is faster than $0.2\mu\text{s}$ and there is no overshoot. The frequency response is specified conservatively as dc to 1 Mc/s, but this is at full power output with less than 3% distortion. The frequency response plotted in Fig. 8 shows that the response is essentially flat to 1 Mc/s and that the 3-dB points occur considerably above 1 Mc/s, depending somewhat on the load. The power output capability as a

function of frequency is diagrammed in Fig. 2 (on front page). This shows the maximum peak-to-peak voltage across a 40-ohm load that it is possible to obtain without waveform clipping. The maximum available output power in any event is not limited by thermal considerations but rather by peak available voltage and current.

The distortion is plotted as a function of frequency in Fig. 6. This shows that the distortion is extremely low in the audio range, in fact so low that it is difficult to measure. Distortion is still well below 3% at 1 Mc/s. Phase shift vs. frequency is shown in Fig. 7. Here it is noted that the phase shift is less than 1% at 10 kc/s and is much less than 45° at 1 Mc/s.

The basic gain of the amplifier is determined by low-temperature-coefficient metal film resistors in the feedback networks and is accurate within 0.1% at dc. In combination with the precision attenuator, this assures an overall gain accuracy of better than 0.3% from dc to 10 kc/s. The input impedance is 50 k ohms shunted by less than 100 pF capacitance.

A relay in the output circuit delays connection to the output for a fraction of a second on turn-on until the amplifier stabilizes. The same relay disconnects the output terminals on turn-off. This protects external circuitry from possible damage caused by output surges on turn-on or turn-off or by line power interruptions. Such surges, often overlooked in amplifier design, are otherwise difficult to avoid. The output transistors are protected from damage resulting from any load condition, including short circuit, by internal current limited power supplies and convection-cooled heat sinks.

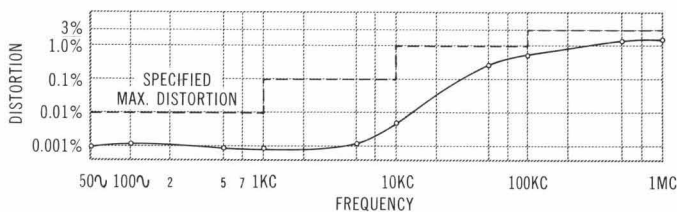

Fig. 6. Harmonic distortion in output of typical amplifier while driving 40-ohm load with 40 V p-p sine wave (5 watts).

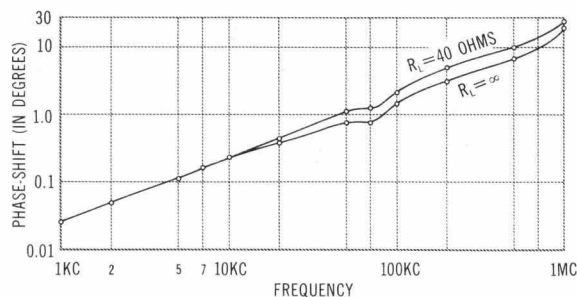

Fig. 7. Typical phase shift in new amplifier as a function of frequency for two values of load resistance.

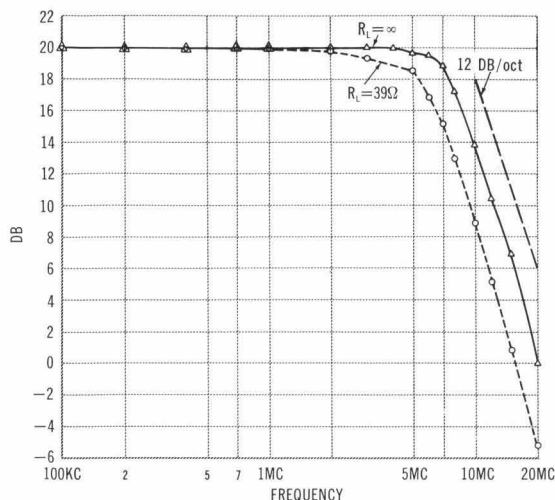

Fig. 8. Typical amplifier small-signal frequency response (below level of voltage or current limiting) is essentially flat to several Mc/s with either low or high impedance load. Ordinate is voltage gain in dB.

APPLICATIONS

The high power capabilities and low output impedance of the new amplifier make it useful in many applications. The low distortion level insures

SPECIFICATIONS	
-hp-	
MODEL 467A	
POWER AMPLIFIER/POWER SUPPLY	
POWER AMPLIFIER	
VOLTAGE GAIN (non-inverting):	
FIXED STEPS: x 1, x 2, x 5, x 10.	
VARIABLE: 0-10, resolution is better than 0.1% of output.	
GAIN ACCURACY: $\pm 0.3\%$ from dc to 10 kc/s with load of 40 or more ohms.	
FREQUENCY RESPONSE (on fixed steps):	
$\pm 1.0\%$ from dc to 100 kc/s $\pm 10\%$ from dc to 1 Mc/s.	
OUTPUT: ± 20 V peak at 0.5 amp peak.	
DISTORTION: Less than 0.01% at 1 kc/s; less than 1% at 100 kc/s; less than 3% at 1 Mc/s.	
INPUT IMPEDANCE: 50k ohms shunted by 100 pF.	
TEMPERATURE COEFFICIENT: Less than ± 2 mV/ $^{\circ}$ C at output.	
DC POWER SUPPLY	
VOLTAGE RANGE: Greater than ± 20 V, ± 10 V, ± 4 V, ± 2 V, ± 1 V; with continuously variable vernier between ranges with resolution better than 0.1% of full output.	
CURRENT: ± 0.5 amp.	
LOAD REGULATION (front panel connector): Less than 10 mV for load change from 0 to 0.5 amp.	
LINE REGULATION: Less than 10 mV for a $\pm 10\%$ change in line voltage.	
TEMPERATURE COEFFICIENT: Less than $\pm 0.05\%$ / $^{\circ}$ C.	
GENERAL	
OUTPUT IMPEDANCE (Front panel connector): Less than 5 milliohms in series with 1 μ H.	
CAPACITIVE LOAD: 0.01 μ F or less does not cause instability.	
RIPPLE AND NOISE: Less than 5 millivolts peak-to-peak at output.	
CURRENT LIMIT: Less than 800 mA.	
INPUT-OUTPUT TERMINALS: Front panel: $\frac{3}{4}$ " spaced banana terminals for input, output, and chassis. Rear panel: BNC terminals for input and output. Amplifier common may be floated 200 V dc above chassis.	
OPERATING TEMPERATURE RANGE: 0 to $+50^{\circ}$ C.	
WEIGHT: Net, 10 lbs. (4.5 kg). Shipping, 16 lbs. (7.2 kg).	
POWER REQUIRED: 115/230 V $\pm 10\%$, 50-1000 c/s; approximately 35 W at full load.	
SIZE: $5\frac{1}{2}$ in. wide x $6\frac{1}{2}$ in. high (with detachable feet) x 11 in. deep behind front panel.	
PRICE: \$575.00.	

Prices f.o.b. factory
Data subject to change without notice

that the power output of oscillators can be increased without impairing performance. The exceptionally low distortion in the audio range means that audio components may be evaluated without concern for signal degradation in the amplifier.

The fast step response and 500-mA current output enable the amplifier to drive magnetic cores or tape recorder heads directly. It may also be used to power incandescent lamps or, with the aid of a step-up transformer, neon lamps to provide excitation for photodiodes or photoconductors. Since full power is available up to 1 Mc/s, the new amplifier can also function as a radio frequency transmitter or as a driver for ultrasonic transducers.

If signals greater than 40 volts p-p are needed, two power amplifiers, driven from a differential source such as the -hp- Model 200CD Oscillator, may be connected as shown in Fig. 10. This enables 80 volts p-p at 1 amp p-p to be obtained.

Because of the gain adjustment provided, the amplifier also functions as an accurate stepped attenuator with 0.1% accuracy or as a continuously variable attenuator with 0.1% resolution.

The small phase shift introduced by the amplifier, as shown in Fig. 7, enhances the use of the amplifier in feedback systems. The positive gain and wide bandwidth allow the new power amplifier to be enclosed in the feedback loop with little difficulty.

One interesting application concerns use of the new power amplifier enclosed in an operational loop with

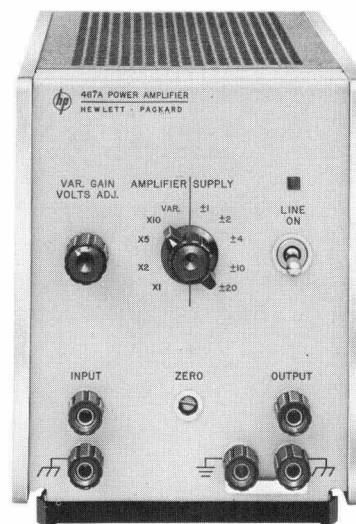

Fig. 9. Model 467A Power Amplifier has maximum output of ± 20 V peak at 0.5 amp peak, and response that extends from dc to beyond 1 Mc/s.

the Dymec Model 2460A Operational Amplifier* as a preamplifier, as shown in Fig. 11. With this combination, the power capabilities of the Model 467A are combined with the low drift and high gain of the Dymec 2460A to make an operational amplifier of exceptional characteristics. Add a d-c motor to the above combination, and it forms a complete servo system.

The amplifier may also be considered a programmable power supply since plus or minus two volts across the input terminals (which draws ± 40 microamps) is sufficient to provide full output. Because of the wide bandwidth inherent in the device, transient recovery time for a $\frac{1}{2}$ -amp current change is less than 50 μ s.

* Robert J. Strehlow, "A Solid-State Operational Amplifier of High Stability," *Hewlett-Packard Journal*, Vol. 14, No. 3-4, Nov.-Dec. 1962.

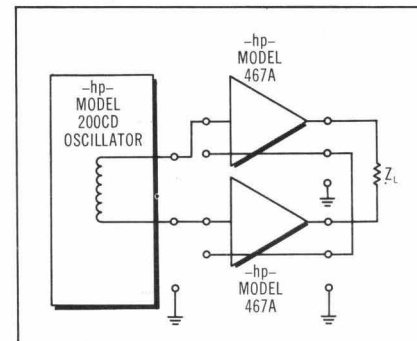

Fig. 10. Use of two power amplifiers in push-pull configuration doubles available output voltage.

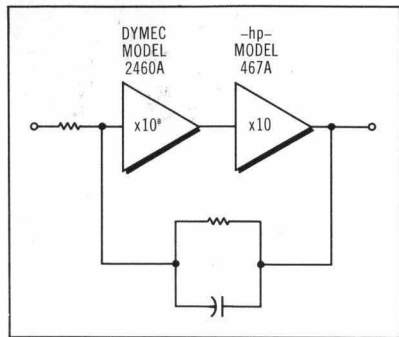
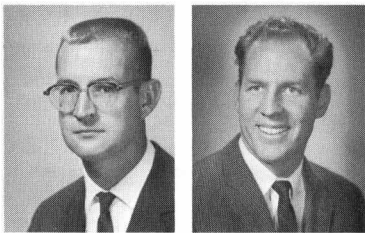

Fig. 11. Use of cascaded high-gain operational amplifier and new power amplifier achieves operational power amplifier of high stability.

MECHANICAL DESIGN

The new *-hp-* Model 467A Power Amplifier/Power Supply is in the *-hp-* 1/3-rack-width module, suitable for use

TEST OSCILLATOR DESIGN LEADERS



Noel M. Pace

Myles A. Judd

Noel Pace, with Hewlett-Packard since 1957, was assigned initially to work as a development engineer on the Model 405A Digital Voltmeter, followed by work on the 457A AC-to-DC Converter. Noel transferred to the *-hp-* Loveland Division in 1961 where he has been concerned with the 403B Transistorized Voltmeter, the 3550A Telephone Test Set, the 465A Amplifier, and the 651A Test Oscillator. He presently is group leader in oscillator and amplifier development within the audio-video section at the Loveland Division.

Noel graduated from Stanford with a BSEE degree and has done graduate study at the University of California. He also served 3 years as a communications officer in the U. S. Army Signal Corps.

Myles Judd joined the *-hp-* Loveland Laboratories as a development engineer in 1962 following graduation from Brigham Young University with the degree of Bachelor of Engineering Science (5-year course). Since joining *-hp-* Myles has worked on precision test oscillators. As a student, he had summertime employment as a junior engineer in logic design for a computer manufacturer.

on the bench or installed with other instruments in a rack adapter. Input and output connectors are provided on both front and rear panels.

The instrument is completely solid-state and is quite compact and cool running compared to vacuum-tube amplifiers in this power range. It consumes only 35 watts at full output. Careful design of the heat sink for the power supply and output transistors allows the dissipation of considerable internal power. In an ambient temperature as high as 50°C, the junction temperatures of the transistors are maintained well within their ratings even at continuous full power output or in short circuit operation.

ACKNOWLEDGMENTS

The *-hp-* Model 467A Power Amplifier/Power Supply was designed in the *-hp-* Advanced Research and Development Laboratories under the direction of Dr. Paul Stoft. Electrical design was by Shelby Givens, Kwang Shih, and the undersigned. Mechanical design was by John A. Bridgham and product support was provided by Robert K. Chipman.

—Robert J. Strehlow

AMPLIFIER DESIGN LEADER



Robert J. Strehlow

Bob Strehlow joined Hewlett-Packard in 1957 as a development engineer after obtaining his BSEE degree from the University of Wisconsin. He has also obtained an MSEE degree at Stanford, under the *-hp-* Honors Cooperative Program, and is currently working toward the degree of Electrical Engineer.

At *-hp-*, Bob first worked with the production aspects of the Model 425A Microvolt-Ammeter and then entered a lengthy research program concerned with photoconductor choppers for low-level dc amplifiers. He also designed the 2460A Operational Amplifier, now produced by the *-hp-* Dymec Division, and worked on the *-hp-* Model 3460A Digital Voltmeter as well as the 467A Power Amplifier. In addition, Bob designed special servomechanism controls for machine tools used in *-hp-* production.

Bob is a member of the IEEE and also belongs to Tau Beta Pi and Eta Kappa Nu.

CYCLES PER SECOND AND HERTZ

A year or so ago the *Hewlett-Packard Journal* published* a table of the SI System of Units of Physical Quantities. This Table had been adopted by the International Conference on Weights and Measures and subsequently by the National Bureau of Standards for use in its publications.

One of the units listed in the table was the unit *hertz* for frequency. As a result of this listing in the *Journal*, many have inquired and urged our adoption of this unit in place of *cycles per second*.

Recently, however, the IEEE, through its Abbreviations Subcommittee of the Symbols Committee, issued a new Standard Symbols for Units (IEEE No. 260, dated January, 1965). This Standard is consistent with most of the units in the International System. With re-

gard to units of frequency, though, the Standard retains *cycles per second (c/s)* with the notation that the International Electrotechnical Commission recommends the name *hertz (Hz)*. Very likely, a major reason for retaining *cycles per second* is the fact that the unit *hertz* is little known in the power field in the U. S.

It is understood that the IEEE, in its publications, will use whichever unit is preferred by an individual author.

The *Hewlett-Packard Journal* has adopted a similar policy, i.e., both *cycles per second* and *hertz* may be used for a transitional time of a year or more. It is expected that full adoption of the unit *hertz* will then be made after this time and after broader knowledge of the unit exists.

* "International System of Units," *Hewlett-Packard Journal*, Vol. 15, No. 7, March, 1965.

—Editor